

DESCRIPTION

The Badger Meter ModMAG[®] M2000 is the result of years of research and field use of electromagnetic flow meter technology. Based on Faraday's law of induction, these meters can measure water, wastewater, water-based fluids and other liquids that meet minimum electrical conductivity.

Designed, developed and manufactured under strict quality standards, this meter features sophisticated, processor-based signal conversion with accuracies of $\pm 0.20\%$ of rate ± 1 mm/s. The wide selection of liner and electrode materials helps provide maximum compatibility and minimum maintenance over a long operating period.

The meter is best suited for bidirectional flow measurement of fluids with a conductivity $> 5 \mu\text{S}/\text{cm}$ ($> 20 \mu\text{S}/\text{cm}$ for demineralized water). The meter has high accuracy, is easy to use, and can be chosen for a wide variety of applications. The backlit, four-line display shows all actual flow measuring data, daily and complete information, including alarm messages. The standard transmitter has 4 programmable digital outputs, one digital input, power output and different interfaces. Integrated system self checkup makes putting into operation and service easier. For service purpose, the meter configuration can be kept or transferred to another meter without a new parametering via the optional back-up parameter function.

APPLICATION

The M2000 transmitter can be integrally mounted to the sensor or can be remote-mounted, if necessary and has many advantages over other conventional technologies. The meter targets a variety of applications and is well suited for the diverse water and wastewater treatment industry. The M2000 meter can accurately measure fluid flow—whether the fluid is water or a highly corrosive liquid, very viscous, contains a moderate amount of solids, or requires special handling. Today, electromagnetic meters are successfully used in industries including building automation, oil and gas, food and beverage, pharmaceutical, water and wastewater, and chemical.



FEATURES

- Available in sizes 0.25...78 in. (6...2000 mm)
- Accuracy of $\pm 0.2\%$ of reading ± 1 mm/s
- Flow Range 0.03...12 m/s
- Pulsed DC magnetic field for zero point stability
- Integral and remote signal converter availability
- Power Supply of 85...265V AC / 9...36V DC
- Corrosion resistant liners for long life
- Measurement largely independent of flow profile
- User friendly programming procedure
- Empty pipe detection
- Power loss totalization
- Digital signal processor (32-bit)
- Non-volatile programming memory
- LCD display
- Rotating cover
- IP67 Housing
- Calibrated in state-of-the-art facilities
- Modbus[®], HART, Profibus DP, M-Bus
- Integrated data logger
- Verifications device
- NSF/ANSI/CAN 61 and 372 listed
- CSA certified

ELECTRODES

When looking from the end of the meter into the inside bore, the two measuring electrodes are positioned at three o'clock and nine o'clock. M2000 electromagnetic meters have an "empty pipe detection" feature. This is accomplished with a third electrode positioned in the meter at twelve o'clock.

If this electrode is not covered by fluid for a minimum five-second duration, the meter displays an "empty pipe detection" condition, sends out an error message, if desired, and stops measuring to maintain accuracy. When the electrode again becomes covered with fluid, the error message disappears and the meter resumes measuring.

As an option to using grounding rings, a grounding electrode (fourth electrode) can be built into the meter during manufacturing to assure proper grounding. The position of this electrode is at six o'clock.

OPERATION

The flow meter is a stainless steel tube lined with a non-conductive material. Outside the tube, two DC powered electromagnetic coils are positioned opposing each other. Perpendicular to these coils, two electrodes are inserted into the flow tube. Energized coils create a magnetic field across the whole diameter of the pipe.

As a conductive fluid flows through the magnetic field, a voltage is induced across the electrodes. This voltage is proportional to the average flow velocity of the fluid and is measured by the two electrodes. The M2000 transmitter receives the sensor's analog signal, amplifies that signal and converts it into digital information. At the processor level, the signal is analyzed through a series of sophisticated software algorithms. After separating the signal from electrical noise, it is converted into both analog and digital signals that are used to display rate of flow and totalization.

With no moving parts in the flow stream, there is no pressure lost. Also, accuracy is not affected by temperature, pressure, viscosity or density and there is practically no maintenance required.

SPECIFICATIONS

NOTE: DN represents nominal diameter in mm.

Transmitter Specifications

Flow Range	0.10...39.4 ft/s (0.03...12 m/s)
Accuracy	± 0.20% m.v. ± 1 mm/s OIML/MID: 2...12 in. (DN50...300) with 0d up and 0d downstream ±1% ≥ 0.5 ft/s (0.15 m/s)
Repeatability	± 0.1%
Power Supply	AC Power Supply: 85...265V AC; Typical Power: 20V A or 15W; Maximum Power: 26V A or 20W Optional DC Power Supply: 10...36V DC; Typical Power: 10W; Maximum Power: 14W
Analog Output	4...20 mA, 0...20 mA, 0...10 mA, 2...10 mA (programmable and scalable) Voltage sourced 24V DC isolated. Maximum loop resistance < 800 Ohms.
Digital Output	Four total, configurable 24V DC sourcing active output (up to 2), 100 mA total, 50 mA each; sinking open collector output (up to four), 30V DC max, 100 mA each; AC solid-state relay (up to 2), 48V AC, 500 mA max
Digital Input	Max 30V DC (programmable – positive zero return, external totalizer reset or preset batch start)
Frequency Output	Scalable up to 10 kHz, open collector up to 1 kHz, solid-state relay
Misc Output	High/low flow alarm (0...100% of flow), error alarm, empty pipe alarm, flow direction, preset batch alarm, 24V DC supply, ADE
Communication	RS232 Modbus RTU; RS485 Modbus RTU, HART, Profibus DP require separate daughterboards
Pulse Width	Scalable up to 10 kHz, passive open collector up to 10 kHz, active switched 24V DC. Up to two outputs (forward and reverse). Pulse width programmable from 1...1000 ms or 50% duty cycle.
Processing	32-bit DSP
Empty Pipe Detection	Field tunable for optimum performance based on specific application
Excitation Frequency	1 Hz, 3.75 Hz, 7.5 Hz or 15 Hz (factory optimized to pipe diameter)
Noise Dampening	Programmable 0...30 seconds
Low Flow Cut-Off	Programmable 0...10% of maximum flow
Galvanic Separation	250V
Fluid Conductivity	Minimum 5.0 µS/cm (minimum 20 µS/cm for demineralized water)
Fluid Temperature	With Remote Transmitter: PFA, PTFE & Halar 302° F (150° C) With Meter-Mounted Transmitter: Rubber 178° F, (80° C), PFA, PTFE & Halar 212° F (100° C)
Ambient Temperature	-4...140° F (-20...60° C)
Relative Humidity	Up to 90 percent non-condensing
Flow Direction	Unidirectional or bidirectional two separate totalizers (programmable)
Totalization	Programmable/resettable
Units of Measure	Ounce, pound, liter, US gallon, imperial gallon, barrel, hectoliter, mega gallon, cubic meter, cubic feet, acre feet
Display	4 x 20 character display with backlight
Programming	Three-button, external manual or remote

Transmitter Housing	Cast aluminum, powder-coated paint		
Mounting	Meter mount or remote wall mount (bracket supplied)		
Locations	Indoor and outdoor		
Meter Enclosure Classification	Standard: NEMA 4X (IP67); Optional: Submersible NEMA 6P ((IP68) depth of 2 m for 72 hr), remote transmitter required		
Junction Box Enclosure Protection	For remote transmitter option: powder-coated die-cast aluminum, NEMA 4 (IP67)		
Cable Entries	M20 cable glands (3)		
Optional Stainless Steel Grounding Rings	Meter Size	Thickness of one ring	Thickness of one ring (DIN Flanges)
	Up through 10 in.	0.135 in. (3.429 mm)	0.12 in. (3 mm)
	12...78 in.	0.187 in. (4.750 mm)	0.12 in. (3 mm)
NSF/ANSI/CAN 61 and 372 Listed	Models with hard rubber liner, 4 in. size and larger; PTFE liner, all sizes		
OIML R49-1 MID MI-001	Size range: DN50...300 / 2...12 in. Minimum straight inlet flow: 0 DN /outlet flow: 0 DN Forward and reverse (bi-directional) flow on any orientation Ratio (Q3/Q1) up to 250 Accuracy Class 1		
Token Features	Data Logging (Blue token); Store/Restore (Red token); Firmware Upgrade (Black token)		

M2000 Transmitter Dimensions
in. (mm)

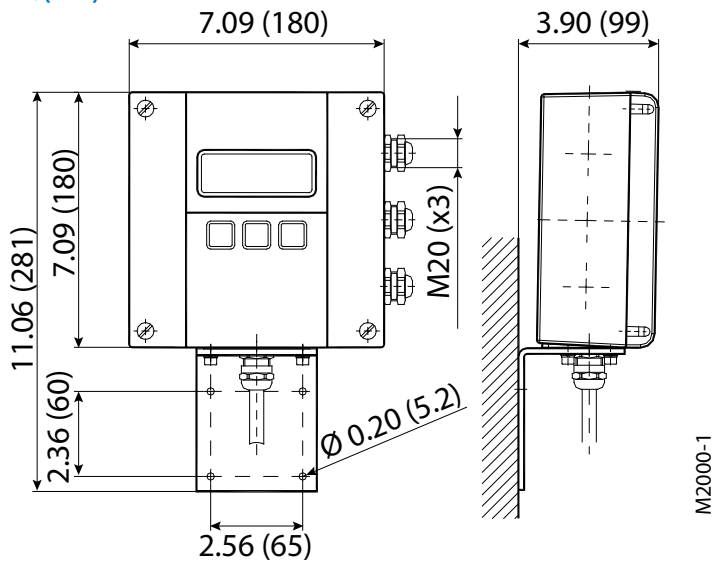

Sensor Type II Specifications

The electromagnetic sensor type II is not only available in a number of different flange process connections (DIN, ANSI, JIS, AWWA) but also in a number of liners like hard rubber, PTFE, PFA, or Halar. The sensor is configurable with up to 4 electrodes for measuring, empty pipe and grounding electrodes. Available in sizes from DN 6 TO DN 2000 and nominal pressures up to PN 100, the sensor type II is best suited for a variety of applications in the industry and the water/waste water industry.

Size	1/4...78 in. (DN 6...2000)	
Flanges	Standard: ANSI B16.5, AWWA, ISO 1092-1, JIS and more in carbon steel; Optional: 304 or 316 stainless steel	
Nominal Pressure	Up to 1450 psi (100 bar)	
Pressure Rating	Line sizes 1/4...24 in: In accordance with ASME B16.5 Class 150 or Flange Rating Class 300 Line sizes 26...72 in: AWWA C-207 Class D or Class E Flange Rating	
Protection Class	NEMA 4X (IP67), optional NEMA 6P (IP68)	
Minimum Conductivity	5 µS/cm (20 µS/cm for demineralized water)	
Liner Material	Hard/soft rubber	1...78 in. (DN 25...2000) 32...176° F (0...80° C)
	PTFE	1/2...24 in. (DN 15...600) -40...302° F (-40...150° C)
	Halar (ECTFE)	12 in. (DN 300) and larger -40...302° F (-40...150° C)
	PFA	1/4...3/8 in. (DN 6...10) —
Electrodes Materials	Hastelloy C (standard), Tantal Platinum / Gold plated, Platinum / Rhodium	
Housing	Standard: Carbon steel welded; Optional: 316 or 304 stainless steel	
Electrode Materials	Standard: Hastelloy C22; Optional: 316 stainless steel, gold/platinum plated, tantalum, platinum/rhodium	
Lay Length	1/4...3/4 in. (DN 6...20)	6.7 in. (170 mm)
	1...2 in. (DN 25...50)	8.9 in. (225 mm)
	2-1/2...4 in. (DN 65...100)	11.0 in. (280 mm)
	5...8 in. (DN 125...200)	15.8 in. (400 mm)
	10...14 in. (DN 250...350)	19.7 in. (500 mm)
	16...28 in. (DN 400...700)	23.6 in. (600 mm)
	30...40 in. (DN 750...1000)	31.5 in. (800 mm)
	48...56 in. (DN 1200...1400)	39.4 in. (1000 mm)
	64 in. (DN 1600)	63.0 in. (1600 mm)
	72 in. (DN 1800)	70.9 in. (1800 mm)
78 in. (DN 2000)	78.7 in. (2000 mm)	

Sensor Type II Dimensions

Remote Version in. (mm)

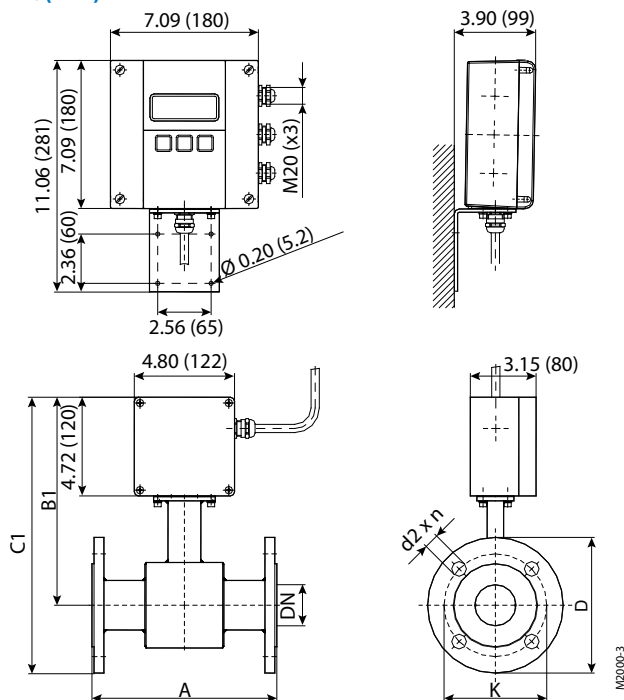

Mounted Version in. (mm)

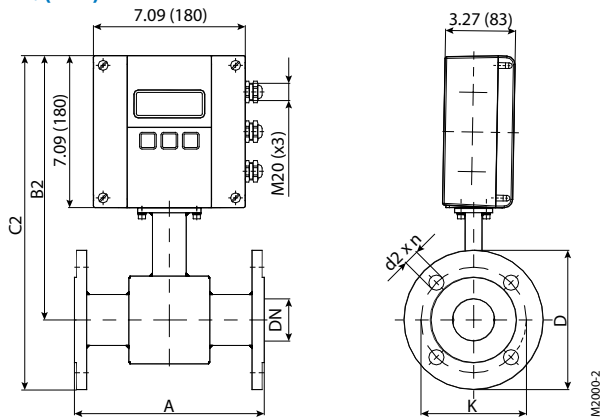

Size		A Std* in. (mm)	A ISO** in. (mm)	B1 in. (mm)	B2 in. (mm)	C1 in. (mm)	C2 in. (mm)	with ANSI-flanges			with DIN-flanges		
in.	DN							Ø D in. (mm)	Ø K in. (mm)	Ø d2×n in. (mm)	Ø D in. (mm)	Ø K in. (mm)	Ø d2×n in. (mm)
1/4	6	6.7 (170)	—	8.98 (228)	11.34 (288)	11.4 (288)	14.0 (356)	3.50 (88.9)	2.37 (60.3)	0.63 × 4 (15.9 × 4)	3.54 (90)	2.36 (60)	0.55 × 4 (14 × 4)
5/16	8	6.7 (170)	—	8.98 (228)	11.34 (288)	11.4 (288)	14.0 (356)	3.50 (88.9)	2.37 (60.3)	0.63 × 4 (15.9 × 4)	3.54 (90)	2.36 (60)	0.55 × 4 (14 × 4)
3/8	10	6.7 (170)	—	8.98 (228)	11.34 (288)	11.4 (288)	14.0 (356)	3.50 (88.9)	2.37 (60.3)	0.63 × 4 (15.9 × 4)	3.54 (90)	2.36 (60)	0.55 × 4 (14 × 4)
1/2	15	6.7 (170)	7.87 (200)	9.37 (238)	11.73 (298)	11.4 (288)	14.0 (356)	3.50 (88.9)	2.37 (60.3)	0.63 × 4 (15.9 × 4)	3.74 (95)	2.56 (65)	0.55 × 4 (14 × 4)
3/4	20	6.7 (170)	7.87 (200)	9.37 (238)	11.73 (298)	11.5 (293)	14.2 (361)	3.87 (98.4)	2.75 (69.8)	0.63 × 4 (15.9 × 4)	4.13 (105)	2.95 (75)	0.55 × 4 (14 × 4)
1	25	8.9 (225)	7.87 (200)	9.37 (238)	11.73 (298)	11.7 (298)	14.4 (366)	4.25 (107.9)	3.13 (79.4)	0.63 × 4 (15.9 × 4)	4.53 (115)	3.35 (85)	0.55 × 4 (14 × 4)
1-1/4	32	8.9 (225)	7.87 (200)	9.96 (253)	12.32 (313)	12.5 (318)	15.2 (386)	4.63 (117.5)	3.50 (88.9)	0.63 × 4 (15.9 × 4)	5.51 (140)	3.94 (100)	0.71 × 4 (18 × 4)
1-1/2	40	8.9 (225)	7.87 (200)	9.96 (253)	12.32 (313)	12.7 (322)	15.4 (390)	5.00 (127)	3.87 (98.4)	0.63 × 4 (15.9 × 4)	5.91 (150)	4.33 (110)	0.71 × 4 (18 × 4)
2	50	8.9 (225)	7.87 (200)	9.96 (253)	12.32 (313)	13.2 (335)	15.9 (403)	6.00 (152.4)	4.75 (120.6)	0.75 × 4 (19 × 4)	6.50 (165)	4.92 (125)	0.71 × 4 (18 × 4)
2-1/2	65	11.0 (280)	7.87 (200)	10.67 (271)	13.05 (331)	14.4 (366)	17.1 (434)	7.00 (177.8)	5.50 (139.7)	0.75 × 4 (19 × 4)	7.28 (185)	5.71 (145)	0.71 × 8 (18 × 8)
3	80	11.0 (280)	7.87 (200)	10.67 (271)	13.05 (331)	14.7 (372)	17.3 (440)	7.50 (190.5)	6.00 (152.4)	0.75 × 4 (19 × 4)	7.87 (200)	6.30 (160)	0.71 × 8 (18 × 8)
4	100	11.0 (280)	9.84 (250)	10.94 (278)	13.31 (338)	15.7 (398)	18.4 (466)	9.00 (228.6)	7.50 (190.5)	0.75 × 8 (19 × 8)	8.66 (220)	7.09 (180)	0.71 × 8 (18 × 8)
5	125	15.8 (400)	9.84 (250)	11.73 (298)	14.09 (358)	16.9 (430)	19.6 (498)	10.00 (254)	8.50 (215.9)	0.85 × 8 (22.2 × 8)	9.84 (250)	8.27 (210)	0.71 × 8 (18 × 8)
6	150	15.8 (400)	11.81 (300)	12.20 (310)	14.57 (370)	17.9 (456)	20.6 (524)	11.00 (279.4)	9.50 (241.3)	0.85 × 8 (22.2 × 8)	11.22 (285)	9.45 (240)	0.87 × 8 (22 × 8)
8	200	15.8 (400)	13.78 (350)	13.31 (338)	15.67 (398)	20.4 (518)	22.5 (572)	13.50 (342.9)	11.75 (298.4)	0.85 × 8 (22.2 × 8)	13.39 (340)	11.61 (295)	0.87 × 12 (22 × 12)
10	250	19.7 (500)	17.72 (450)	14.25 (362)	16.61 (422)	24.1 (613)	26.8 (681)	16.00 (406.4)	14.25 (361.9)	1.00 × 12 (25.4 × 12)	15.55 (395)	13.78 (350)	0.87 × 12 (22 × 12)
12	300	19.7 (500)	19.69 (500)	16.73 (425)	19.09 (485)	26.2 (666)	28.9 (734)	19.00 (482.6)	17.00 (431.8)	1.00 × 12 (25.4 × 12)	17.52 (445)	15.75 (400)	0.87 × 12 (22 × 12)
14	350	19.7 (500)	21.65 (550)	17.72 (450)	20.08 (510)	28.2 (716)	30.8 (782)	21.00 (533.4)	18.75 (476.2)	1.13 × 12 (28.6 × 12)	19.88 (505)	18.11 (460)	0.87 × 16 (22 × 16)
16	400	23.6 (600)	23.62 (600)	18.70 (475)	21.06 (535)	31.0 (788)	33.7 (856)	23.50 (596.9)	21.25 (539.7)	1.13 × 16 (28.6 × 16)	22.24 (565)	20.28 (515)	1.02 × 16 (26 × 16)
18	450	23.6 (600)	—	19.69 (500)	22.05 (560)	32.4 (822)	35.0 (890)	25.00 (635.0)	22.75 (577.8)	1.25 × 16 31.7 × 16	24.21 (615)	22.24 (565)	1.02 × 20 (26 × 20)
20	500	23.6 (600)	—	20.67 (525)	23.03 (585)	35.5 (901)	38.2 (969)	27.50 (698.5)	25.00 (635.0)	1.25 × 20 (31.7 × 20)	26.38 (670)	24.41 (620)	1.02 × 20 (26 × 20)
22	550	23.6 (600)	—	21.65 (550)	24.02 (610)	36.9 (937)	39.6 (1005)	29.50 (749.3)	27.25 (692.1)	1.37 × 20 (34.9 × 20)	—	—	—
24	600	23.6 (600)	—	23.15 (588)	25.51 (648)	39.5 (1003)	42.2 (1071)	32.00 (812.8)	29.50 (749.3)	1.37 × 20 (34.9 × 20)	30.71 (780)	28.54 (725)	1.18 × 20 (30 × 20)
26	650	23.6 (600)	—	24.13 (613)	26.50 (673)	—	—	32.25 (869.9)	31.75 (806.4)	1.37 × 24 (34.9 × 24)	—	—	—
28	700	23.6 (600)	—	24.61 (625)	26.97 (685)	44.0 (1118)	46.2 (1173)	36.50 (927.1)	34.00 (863.6)	1.38 × 28 (35.1 × 28)	35.24 (895)	33.07 (840)	1.18 × 24 (30 × 24)
30	750	31.5 (800)	—	25.59 (650)	27.95 (710)	45.7 (1161)	48.3 (1228)	38.75 (984.2)	36.00 (914.4)	1.37 × 28 (34.9 × 28)	—	—	—
32	800	31.5 (800)	—	26.89 (683)	29.25 (743)	49.5 (1257)	52.2 (1325)	41.75 (1060.5)	38.50 (977.9)	1.63 × 28 (41.3 × 28)	39.96 (1015)	37.40 (950)	1.30 × 24 (33 × 24)
34	850	31.5 (800)	—	27.87 (708)	30.24 (768)	—	—	43.75 (1111.2)	40.50 (1028.7)	1.63 × 32 (41.3 × 32)	—	—	—
36	900	31.5 (800)	—	28.54 (725)	30.91 (785)	54.1 (1374)	55.3 (1405)	46.00 (1168.4)	42.75 (1085.8)	1.63 × 32 (41.3 × 32)	43.90 (1115)	41.34 (1050)	1.30 × 28 (33 × 28)
38	950	31.5 (800)	—	29.53 (750)	31.89 (810)	—	—	48.75 (1238.3)	45.25 (1149.4)	1.63 × 32 (41.3 × 32)	—	—	—
40	1000	31.5 (800)	—	31.10 (790)	33.46 (850)	57.4 (1457)	60.0 (1525)	53.00 (1346.2)	49.50 (1257.3)	1.63 × 36 (41.3 × 36)	48.43 (1230)	45.67 (1160)	1.42 × 28 (36 × 28)

Size		A Std* in. (mm)	A ISO** in. (mm)	B1 in. (mm)	B2 in. (mm)	C1 in. (mm)	C2 in. (mm)	with ANSI-flanges			with DIN-flanges		
in.	DN							Ø D in. (mm)	Ø K in. (mm)	Ø d2xn in. (mm)	Ø D in. (mm)	Ø K in. (mm)	Ø d2xn in. (mm)
42	1050	39.4 (1000)	—	—	—	63.4 (1610)	66.0 (1675)	—	—	—	—	—	—
48	1200	39.4 (1000)	—	35.43 (900)	37.80 (960)	67.2 (1707)	69.9 (1775)	59.51 (1511.5)	56.00 (1422.4)	1.63 × 44 (41.3 × 44)	57.28 (1455)	54.33 (1380)	1.54 × 32 (39 × 32)
54	1350	39.4 (1000)	—	38.39 (975)	40.75 (1035)	73.0 (1927)	75.4 (1915)	66.25 (1682.8)	62.75 (1593.9)	1.88 × 44 (47.8 × 44)	—	—	—
56	1400	39.4 (1000)	—	39.37 (1000)	41.73 (1060)	—	—	—	—	—	65.94 (1675)	62.60 (1590)	1.65 × 36 (42 × 36)
Standard													
with ANSI-flanges		1/4...56 in. (DN 6 - 1400)				pressure rate 150 psi (10 bar)							
with DIN flanges		1/4...8 in. (DN 6 – 200)				pressure rate 230 psi (16 bar)							
		10...56 in. (DN 250 – 1400)				pressure rate 150 psi (10 bar)							
* Standard		**ISO 20456											

IMPORTANT

Flange Sizes ≤ 24 in., Standard: ANSI B16.5 Class 150 RF forged carbon steel; Optional: 300 lb forged carbon steel, 316 or 304 stainless steel

Flange Sizes > 24 in., Standard: AWWA Class D Flanges RF forged carbon steel

Weight and Flow Range

Size		Estimated Weight with M2000	Flow Range	
in.	DN		lb (kg)	US Metric
1/4	6	8 (3.5)	0.0134...5.4 GPM	0.051...20.4 l/min
5/16	8	8 (3.5)	0.0239...9.6 GPM	0.09...36.2 l/min
3/8	10	8 (3.5)	0.0373...14.9 GPM	0.141...57 l/min
1/2	15	10 (4.5)	0.084...33.6 GPM	0.318...127 l/min
3/4	20	10 (4.5)	0.149...60 GPM	0.57...226 l/min
1	25	11 (5)	0.233...93 GPM	0.88...353 l/min
1-1/4	32	13 (6)	0.382...153 GPM	1.45...579 l/min
1-1/2	40	15.5 (7)	0.6...239 GPM	2.26...905 l/min
2	50	19 (8.5)	0.93...373 GPM	3.53...1,414 l/min
2-1/2	65	27.5 (12.5)	1.58...631 GPM	0.358...143 m ³ /h
3	80	31 (14)	2.39...956 GPM	0.54...217 m ³ /h
4	100	42 (19)	3.73...1,494 GPM	0.85...339 m ³ /h
5	125	53 (24)	5.8...2,334 GPM	1.33...530 m ³ /h
6	150	60.5 (27.5)	8.4...3,361 GPM	1.91...763 m ³ /h
8	200	87 (39.5)	14.9...5,975 GPM	3.39...1,357 m ³ /h
10	250	129 (58.5)	23.3...9,336 GPM	5.3...2,121 m ³ /h
12	300	204 (92.5)	33.6...13,444 GPM	7.6...3,054 m ³ /h
14	350	262 (119)	45.7...18,299 GPM	10.4...4,156 m ³ /h
16	400	344 (156)	60...23,901 GPM	13.6...5,429 m ³ /h
18	450	397 (180)	76...30,250 GPM	17.2...6,870 m ³ /h
20	500	470 (213)	93...37,345 GPM	21.2...8,482 m ³ /h
22	550	549 (249)	113...45,188 GPM	25.7...10,263 m ³ /h
24	600	617 (280)	134...53,777 GPM	30.5...12,214 m ³ /h
28	700	—	183...73,197 GPM	41.6...16,625 m ³ /h
30	750	930 (422)	210...84,027 GPM	47.7...19,085 m ³ /h
32	800	1171 (531)	239...95,604 GPM	54.3...21,714 m ³ /h
36	900	1378 (625)	302...120,999 GPM	69...27,482 m ³ /h
40	1000	—	373...149,381 GPM	85...33,928 m ³ /h
48	1200	1788 (811)	538...215,109 GPM	122...48,857 m ³ /h
56	1400	—	732...292,787 GPM	166...66,499 m ³ /h
60	1500	2112 (958)	840...336,108 GPM	191...76,338 m ³ /h
64	1600	2339 (1061)	956...382,416 GPM	217...86,856 m ³ /h
72	1800	3219 (1460)	1210...483,996 GPM	275...109,927 m ³ /h
78	2000	4101 (1860)	1494...597,525 GPM	339...135,713 m ³ /h

Sensor Type III Specifications

Thanks to its very short lay length, the sensor type III is often the right alternative to a lot of applications. Delivered with a PTFE liner, the sensor type III has a standard nominal pressure of PN 40.

Size	1...4 in. (DN 25...100)	
Process Connection	Wafer connection (in-between flange mounting)	
Nominal Pressure	580 psi (40 bar)	
Protection Class	NEMA 4X (IP67), optional NEMA 6P (IP68)	
Minimum Conductivity	5 µS/cm (20 µS/cm for demineralized water)	
Liner Materials	PTFE	
Electrode Material	Hastelloy C (Standard), Tantal, Platinum / Gold Plated, Platinum / Rhodium	
Housing	Carbon Steel / optional stainless steel	
Lay Length	1...2 in. (DN 25...50)	4 in. (100 mm)
	2-1/2...4 in. (DN 65...100)	6 in. (150 mm)

Sensor Type III Dimensions

Remote Version in. (mm)

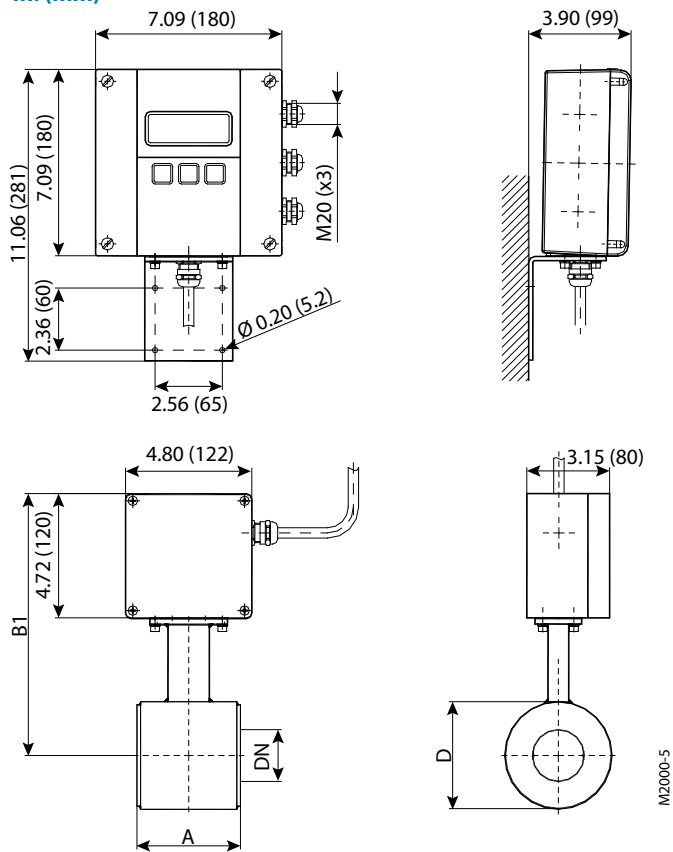

Mounted Version in. (mm)

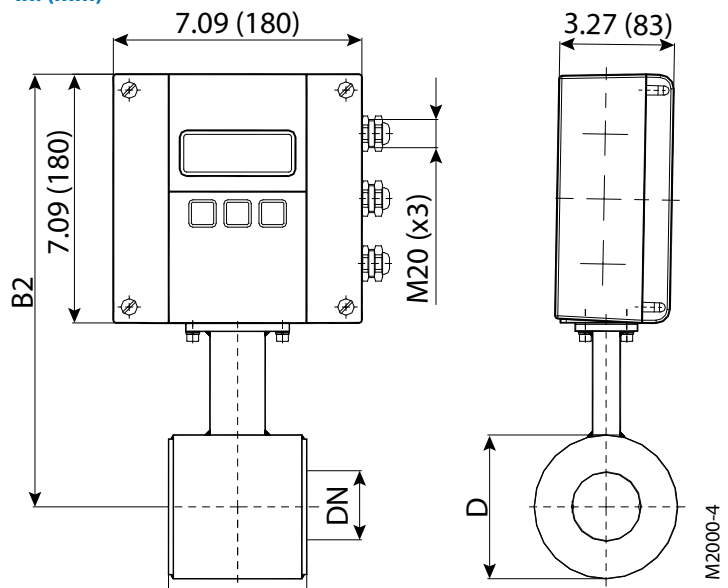

in.	DN	A	B1	B2	D
1	25	3.94 (100)	9.37 (238)	7.24 (184)	2.91 (74)
1-1/4	32	3.94 (100)	9.57 (243)	7.44 (189)	3.31 (84)
1-1/2	40	3.94 (100)	9.76 (248)	7.64 (194)	3.70 (94)
2	50	3.94 (100)	9.96 (253)	7.83 (199)	4.09 (104)
2-1/2	65	5.91 (150)	10.47 (266)	8.35 (212)	5.08 (129)
3	80	5.91 (150)	10.67 (271)	8.54 (217)	5.51 (140)
4	100	5.91 (150)	10.98 (279)	8.86 (225)	6.14 (156)

580 psi (40 bar)

Sensor with Sanitary Process Connections Specifications

The sensor model is available with Tri-Clamp® BS4825/ISO2852, DIN11851, and more process connections. The sanitary sensor is delivered in a stainless steel housing and with PTFE/PFA lining.

Size	3/8...4 in. (DN 10...100)		
Process Connection	Tri-Clamp BS4825/ISO2852, DIN 11851, customer specified, and more		
Nominal Pressure	145/230 psi (10/16 bar)		
Protection Class	NEMA 4X (IP67), optional NEMA 6P (IP68)		
Minimum Conductivity	5 µS/cm (20 µS/cm for demineralized water)		
Liner Materials	PTFE/PFA	-40...302° F (-40...150° C)	
Electrode Material	Standard: Hastelloy C; Optional: Tantal, Platinum / Gold plated, Platinum / Rhodium		
Housing	Standard: Carbon Steel; Optional: Stainless Steel		
Lay Length	Tri-Clamp Connection	3/8...2 in. (DN 10...50)	6 in. (145 mm)
		2-1/2...4 in. (DN 65...100)	8 in. (200 mm)
	DIN 11851 Connection	3/8...3/4 in. (DN 10...20)	7 in. (175 mm)
		1...2 in. (DN 25...50)	9 in. (225 mm)
		2-1/2...4 in. (DN 65...100)	11 in. (280 mm)

DIN 11851 Connection Dimensions

Remote Version in. (mm)

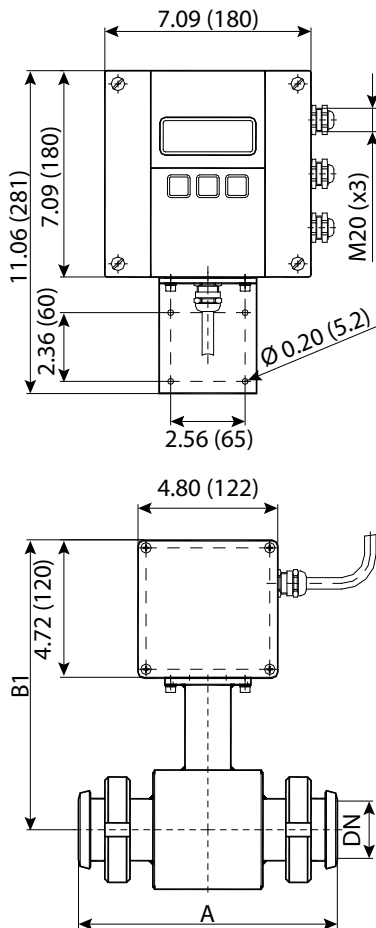

Mounted Version in. mm

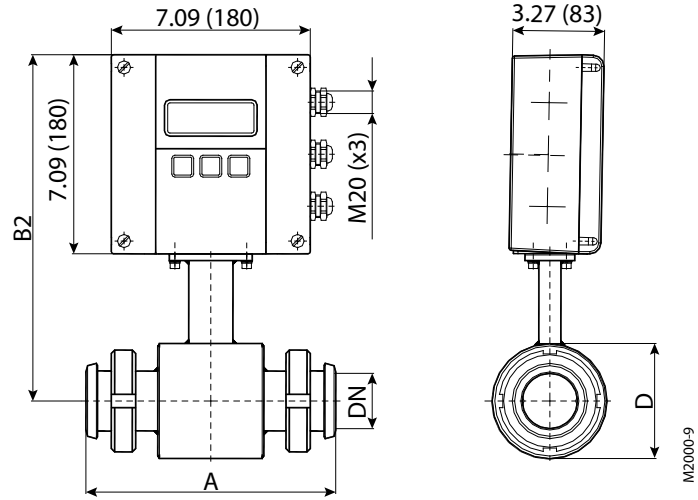

in.	DN	A	B1	B2	D
3/8	10	6.69 (170)	9.37 (238)	7.24 (184)	2.91 (74)
1/2	15	6.69 (170)	9.37 (238)	7.24 (184)	2.91 (74)
3/4	20	6.69 (170)	9.37 (238)	7.24 (184)	2.91 (74)
1	25	8.86 (225)	9.37 (238)	7.24 (184)	2.91 (74)
1-1/4	32	8.86 (225)	9.57 (243)	7.44 (189)	3.31 (84)
1-1/2	40	8.86 (225)	9.76 (248)	7.64 (194)	3.70 (94)
2	50	8.86 (225)	9.96 (253)	7.83 (199)	4.09 (104)
2-1/2	65	11.02 (280)	10.47 (266)	8.35 (212)	5.08 (129)
3	80	11.02 (280)	10.67 (271)	8.54 (217)	5.51 (140)
4	100	11.02 (280)	10.98 (279)	8.86 (225)	6.14 (156)
230 psi (16 bar)					

Tri-Clamp Connection Dimensions

Remote Version in. (mm)

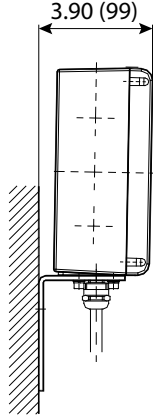
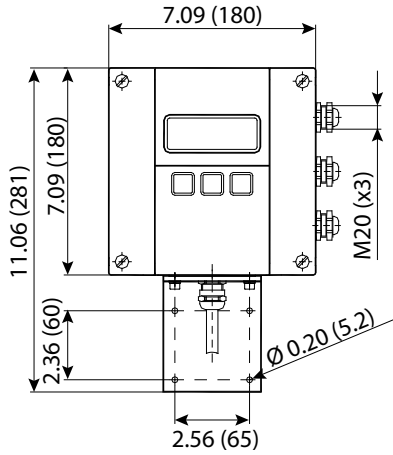

Mounted Version in. (mm)

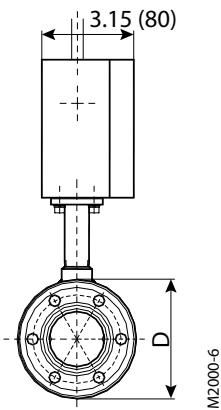
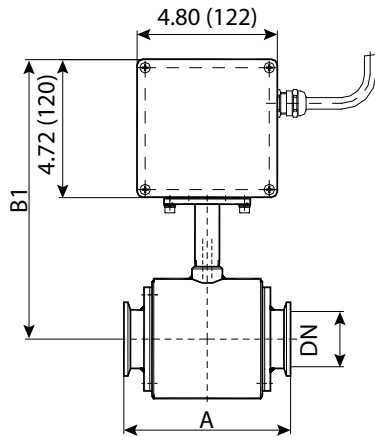
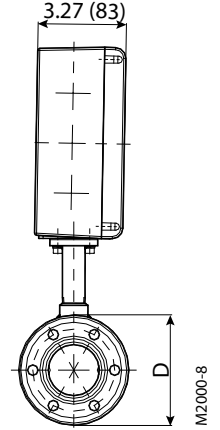
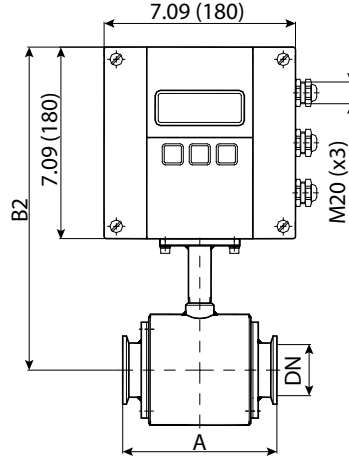

in.	DN	A	B1	B2	D
3/8	10	5.71 (145)	8.98 (228)	7.52 (191)	2.91 (74)
1/2	15	5.71 (145)	8.98 (228)	7.52 (191)	2.91 (74)
3/4	20	5.71 (145)	8.98 (228)	7.52 (191)	2.91 (74)
1	25	5.71 (145)	8.98 (228)	7.52 (191)	2.91 (74)
1-1/2	40	5.71 (145)	9.37 (238)	7.91 (201)	3.70 (94)
2	50	5.71 (145)	9.57 (243)	8.11 (206)	4.09 (104)
2-1/2	65	7.87 (200)	10.08 (256)	8.62 (219)	5.08 (129)
3	80	7.87 (200)	10.28 (261)	8.82 (224)	5.51 (140)
4	100	7.87 (200)	10.59 (269)	9.13 (232)	6.14 (156)

150 psi (10 bar)

Tri-Clamp Connection

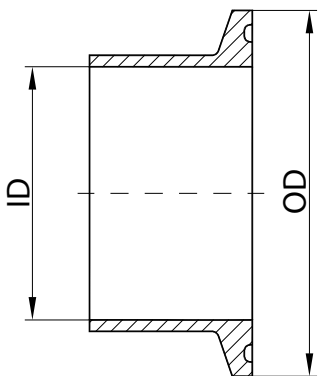

BS4825					ISO2852				
Size	OD		ID		Size	OD		ID	
in.	in.	mm	in.	mm	DN	in.	mm	in.	mm
—	—	—	—	—	10	0.98	25.0	0.55	14.0
1/2	0.98	25.0	0.37	9.4	15	1.99	50.5	0.71	18.1
3/4	0.98	25.0	0.62	15.75	20	1.99	50.5	0.90	22.9
1	1.99	50.5	0.87	22.1	25	1.99	50.5	1.13	28.7
—	—	—	—	—	32	2.52	64.0	1.51	38.4
1-1/2	1.99	50.5	1.37	34.8	40	2.52	64.0	1.74	44.3
2	2.52	64.0	1.87	47.5	50	3.05	77.5	2.22	56.3
2-1/2	3.05	77.5	2.37	60.2	65	3.58	91.0	2.84	72.1
3	3.58	91.0	2.87	72.9	80	4.17	106.0	3.32	84.3
4	4.69	119.0	3.83	97.4	100	5.12	130.0	4.32	109.7

Nominal Pressure 145 psi (10 bar)

PART NUMBER CONSTRUCTION

If you are interested in a product configuration that is not designated for your region, please contact Badger Meter.

Sensor and Transmitter Ordering Information for North America

Hard Rubber Liner

M2	Meter Type	Detector	Electrodes & Grounding	Amplifier	Remote Cable Length	Communications/ Outputs	Wiring Method	Unit of Measure Totalizer/ Flow Rate	Testing & Tagging
		HARD RUBBER C-Steel 150# Flanges R1	HARD RUBBER C-Steel 300# Flanges R2	HARD RUBBER Stainless Steel 150# Flanges R4					
Meter Type-Standard LL									
	1/4 in.	002	N/A	N/A					
	3/16 in.	003	N/A	N/A					
	3/8 in.	004	N/A	N/A					
	1/2 in.	005	N/A	N/A					
	3/4 in.	007	N/A	N/A					
	1 in.	010							
	1-1/4 in.	012							
	1-1/2 in.	015							
	2 in.	020							
	2-1/2 in.	025							
	3 in.	030							
	4 in.	040							
	5 in.	050							
	6 in.	060							
	8 in.	080							
	10 in.	100							
	12 in.	120							
	14 in.	140							
	16 in.	160							
	18 in.	180							
	20 in.	200							
	22 in.	220							
	24 in.	240							
	28 in.	280							
	30 in.	300							
	32 in.	320							
	36 in.	360							
	40 in.	400		N/A					
	42 in.	420		N/A					
	48 in.	480		N/A					
	54 in.	540		N/A					
	Electrodes & Grounding								
	Alloy C with 316 Stainless Steel Grounding Rings			A					
	Stainless Steel with 316 Stainless Steel Grounding Rings			S					
	Platinum Plated with 316 Stainless Steel Grounding Rings			P					
	Tantalum with 316 Stainless Steel Grounding Rings			T					
	Platinum/Rhodium with 316 Stainless Steel Grounding Rings			R					
	Alloy C Electrode and Grounding Electrode			C					
	Stainless Steel Electrode and Grounding Electrode			D					
	Platinum Plated Electrode and Grounding Electrode			G					
	Tantalum Electrode and Grounding Electrode			L					
	Platinum/Rhodium Electrode and Grounding Electrode			H					
	Amplifier Type								
	110/220V AC; Meter Mounted			M					
	110/220V AC; Remote Mounted			R					
	110/220V AC; Remote Mounted; Submersible			S					
	110/220V AC; Remote Mounted; Submersible (IP68)			T					
	24V DC; Meter Mounted			E					
	24V DC; Remote Mounted			F					
	24V DC; Remote Mounted; Submersible			G					
	24V DC; Remote Mounted; Submersible (IP68)			B					
	Remote Cable Length								
	None				WW				
	5 ft. Standard Cable				AA				
	10 ft. Standard Cable				AB				
	15 ft. Standard Cable				AC				
	30 ft. Standard Cable				AF				
	50 ft. Standard Cable				AS				
	75 ft. Standard Cable				AR				
	100 ft. Standard Cable				BW				
	125 ft. Standard Cable				BE				
	150 ft. Standard Cable				BK				
	175 ft. Standard Cable				BR				
	200 ft. Standard Cable				DW				
	225 ft. Standard Cable				DE				
	250 ft. Standard Cable				DK				
	275 ft. Standard Cable				DR				
	300 ft. Standard Cable				EW				
	325 ft. Standard Cable				EE				
	350 ft. Standard Cable				EK				
	375 ft. Standard Cable				ER				
	400 ft. Standard Cable				FW				
	425 ft. Standard Cable				FE				
	450 ft. Standard Cable				FK				
	475 ft. Standard Cable				FR				
	500 ft. Standard Cable				GW				
	Communication/Outputs								
	Standard Output					S			
	Standard Output with HART					H			
	Standard Output with PROFIBUS DP					P			
	Standard Output with MODBUS 485 RTU					M			
	Wiring Method								
	None						XX		
	Twist Tight - 5 ft. (MTR, ASSY)						TF		
	Twist Tight - 10 ft. (MTR, ASSY)						TH		
	Twist Tight - 25 ft. (MTR, ASSY)						TJ		
	Twist Tight - 75 ft. (MTR, ASSY)						TK		
	Nicor - 6 ft. (MTR, ASSY)						NG		
	Nicor - 25 ft. (MTR, ASSY)						NJ		
	Iron - 5 ft. (MTR, ASSY)						CF		
	Iron - 25 ft. (MTR, ASSY)						CJ		
	Unit of Measure Totalizer/ Flow Rate								
	Gallons/gallons per minute							G	
	Gallons/cubic feet per minute							B	
	Gallons/cubic meters per second							C	
	Cubic Meters/gallons per minute							D	
	Cubic Meters/cubic meters per second							E	
	Cubic Meters/cubic meters per minute							T	
	Cubic Meters/cubic meters per hour							H	
	Cubic Feet/gallons per minute							F	
	Cubic Feet/cubic feet per minute							BE	
	Cubic Feet/cubic meters per hour							K	
	Liters/gallons per minute							L	
	Liters/liters per second							N	
	Liters/liters per minute							P	
	Liters/liters per hour							Q	
	Million Gallons/gallons per minute							M	
	Gallons/millions gallons per day							R	
	Acre Feet/gallons per minute							A	
	Second-Foot Day/cubic feet per second							S	
	Custom Units							Z	
	Testing & Tagging								
	Factory Calibrated								F
	3rd Party Calibrated (See pricing on pg. 20)								3
	Factory Calibrated/Stainless Steel Tag								S
	3rd Party Calibrated w/ Stainless Steel Tag (See pricing on pg. 20)								T
	State of Kansas Certified								K

Sensor and Transmitter Ordering Information for North America

PTFE Liner

M2000	Meter Type	Detector					Electrodes & Grounding	Amplifier	Remote Cable Length	Communications/Outputs	Wiring Method	Unit of Measure Totalizer/ Flow Rate	Testing and Tagging
		PTFE C-Steel 150# flanges	PTFE C-Steel 300# flanges	PTFE Stainless Steel 150# flanges	PFA Steel 150# Flanges	Stainless Steel 150# Flanges							
Meter Type- Standard LL													
1/4 in.	002	P1	P2	P4	PA								
5/16 in.	003	N/A	N/A	N/A	N/A								
3/8 in.	004	N/A	N/A	N/A	N/A								
1/2 in.	005	—	—	—	—								
3/4 in.	007	—	—	—	—								
1 in.	010	—	—	—	—								
1-1/4 in.	012	—	—	—	—								
1-1/2 in.	015	—	—	—	—								
2 in.	020	—	—	—	—								
2-1/2 in.	025	—	—	—	—								
3 in.	030	—	—	—	—								
4 in.	040	—	—	—	—								
5 in.	050	—	—	—	—								
6 in.	060	—	—	—	—								
8 in.	080	—	—	—	—								
10 in.	100	—	—	—	—								
12 in.	120	—	—	—	—								
14 in.	140	—	—	—	—								
16 in.	160	—	—	—	—								
18 in.	180	—	—	—	—								
20 in.	200	—	—	—	—								
22 in.	220	—	—	—	—								
24 in.	240	—	—	—	—								
28 in.	280	N/A	N/A	N/A	N/A								
30 in.	300	N/A	N/A	N/A	N/A								
32 in.	320	N/A	N/A	N/A	N/A								
36 in.	360	N/A	N/A	N/A	N/A								
40 in.	400	N/A	N/A	N/A	N/A								
42 in.	420	N/A	N/A	N/A	N/A								
48 in.	480	N/A	N/A	N/A	N/A								
54 in.	540	N/A	N/A	N/A	N/A								
Electrodes & Grounding													
Alloy C with 316 Stainless Steel Grounding Rings						A							
Stainless Steel with 316 Stainless Steel Grounding Rings						S							
Platinum Plated with 316 Stainless Steel Grounding Rings						P							
Tantalum with 316 Stainless Steel Grounding Rings						T							
Platinum/Rhodium with 316 Stainless Steel Grounding Rings						R							
Alloy C Electrode and Grounding Electrode						C							
Stainless Steel Electrode and Grounding Electrode						D							
Platinum Plated Electrode and Grounding Electrode						G							
Tantalum Electrode and Grounding Electrode						L							
Platinum/Rhodium Electrode and Grounding Electrode						H							
Amplifier Type													
110/220V AC; Meter Mounted						M							
110/220V AC; Remote Mounted						R							
110/220V AC; Remote Mounted; Submersible						S							
110/220V AC; Remote Mounted; Submersible (IP68)						T							
24V DC; Meter Mounted						E							
24V DC; Remote Mounted						F							
24V DC; Remote Mounted; Submersible						G							
24V DC; Remote Mounted; Submersible (IP68)						B							
Remote Cable Length													
None						WW							
5 ft. Standard Cable						AA							
10 ft. Standard Cable						AB							
15 ft. Standard Cable						AC							
30 ft. Standard Cable						AF							
50 ft. Standard Cable						AK							
75 ft. Standard Cable						AR							
100 ft. Standard Cable						BW							
125 ft. Standard Cable						BE							
150 ft. Standard Cable						BK							
175 ft. Standard Cable						BR							
200 ft. Standard Cable						DW							
225 ft. Standard Cable						DE							
250 ft. Standard Cable						DK							
275 ft. Standard Cable						DR							
300 ft. Standard Cable						DW							
325 ft. Standard Cable						EE							
350 ft. Standard Cable						EK							
375 ft. Standard Cable						ER							
400 ft. Standard Cable						FW							
425 ft. Standard Cable						FE							
450 ft. Standard Cable						FK							
475 ft. Standard Cable						FR							
500 ft. Standard Cable						GW							
Communications/Outputs													
Standard Output						S							
Standard Output with HART						H							
Standard Output with PROFIBUS DP						P							
Standard Output with MODBUS 485 RTU						M							
Wiring Method													
None							XX						
Twist Tight - 5 ft. (MTR, ASSY)							TF						
Twist Tight - 10 ft. (MTR, ASSY)							TH						
Twist Tight - 25 ft. (MTR, ASSY)							TJ						
Twist Tight - 75 ft. (MTR, ASSY)							TK						
Nicor - 6 ft. (MTR, ASSY)							NG						
Nicor - 25 ft. (MTR, ASSY)							NJ						
Itron - 5 ft. (MTR, ASSY)							CF						
Itron - 25 ft. (MTR, ASSY)							CJ						
Unit of Measure Totalizer/ Flow Rate													
Gallons/gallons per minute							G						
Gallons/cubic feet per minute							B						
Gallons/cubic meters per second							D						
Cubic Meters/gallons per minute							C						
Cubic Meters/cubic meters per second							E						
Cubic Meters/cubic meters per minute							T						
Cubic Meters/cubic meters per hour							H						
Cubic Feet/gallons per minute							F						
Cubic Feet/cubic feet per minute							J						
Cubic Feet/cubic meters per hour							K						
Liters/gallons per minute							L						
Liters/liters per second							N						
Liters/liters per minute							P						
Liters/liters per hour							Q						
Million Gallons/gallons per minute							M						
Gallons/millions gallons per day							R						
Acre Feet/gallons per minute							A						
Second-Foot Day/cubic feet per second							S						
Custom Units							Z						
Testing & Tagging													
Factory Calibrated							F						
3rd Party Calibrated (See pricing on pg. 20)							3						
Factory Calibrated/Stainless Steel Tag							S						
3rd Party Calibrated w/ Stainless Steel Tag (See pricing on pg. 20)							T						
State of Kansas Certified							K						

Sensor and Transmitter Ordering Information for North America

Halar Liner

M2	Meter Type	Detector			Electrodes & Grounding	Amplifier	Remote Cable Length	Communications/Outputs	Wiring Method	Unit of Measure Totalizer/Flow Rate	Testing & Tagging
		HALAR C-Steel 150# flanges	HALAR C-Steel 300# flanges	HALAR Stainless Steel 150# flanges							
		H1	H2	H4							
Meter Type- Standard LL											
14 in.	140	—	—	—							
16 in.	160	—	—	—							
18 in.	180	—	—	—							
20 in.	200	—	—	—							
22 in.	220	—	—	—							
24 in.	240	—	—	—							
28 in.	280	—	—	—							
30 in.	300	—	—	—							
32 in.	320	—	—	—							
36 in.	360	—	—	—							
40 in.	400	—	N/A	—							
Electrodes & Grounding											
Alloy C with 316 Stainless Steel Grounding Rings					A						
Stainless Steel with 316 Stainless Steel Grounding Rings					S						
Platinum Plated with 316 Stainless Steel Grounding Rings					P						
Tantalum with 316 Stainless Steel Grounding Rings					T						
Platinum/Rhodium with 316 Stainless Steel Grounding Rings					R						
Alloy C Electrode and Grounding Electrode					C						
Stainless Steel Electrode and Grounding Electrode					D						
Platinum Plated Electrode and Grounding Electrode					G						
Tantalum Electrode and Grounding Electrode					L						
Platinum/Rhodium Electrode and Grounding Electrode					H						
Amplifier Type											
110/220V AC; Meter Mounted					M						
110/220V AC; Remote Mounted					R						
110/220V AC; Remote Mounted; Submersible					S						
110/220V AC; Remote Mounted; Submersible (IP68)					T						
24V DC; Meter Mounted					E						
24V DC; Remote Mounted					F						
24V DC; Remote Mounted; Submersible					G						
24V DC; Remote Mounted; Submersible (IP68)					B						
Remote Cable Length											
None						WW					
5 ft. Standard Cable						AA					
10 ft. Standard Cable						AB					
15 ft. Standard Cable						AC					
30 ft. Standard Cable						AF					
50 ft. Standard Cable						AK					
75 ft. Standard Cable						AR					
100 ft. Standard Cable						BW					
125 ft. Standard Cable						BE					
150 ft. Standard Cable						BK					
175 ft. Standard Cable						BR					
200 ft. Standard Cable						DW					
225 ft. Standard Cable						DE					
250 ft. Standard Cable						DK					
275 ft. Standard Cable						DR					
300 ft. Standard Cable						EW					
325 ft. Standard Cable						EE					
350 ft. Standard Cable						EK					
375 ft. Standard Cable						ER					
400 ft. Standard Cable						FW					
425 ft. Standard Cable						FE					
450 ft. Standard Cable						FK					
475 ft. Standard Cable						FR					
500 ft. Standard Cable						GW					
Communications/Outputs											
Standard Output							S				
Standard Output with HART							H				
Standard Output with PROFIBUS DP							P				
Standard Output with MODBUS 485 RTU							M				
Wiring Method											
None								XX			
Twist Tight - 5 ft. (MTR, ASSY)								TF			
Twist Tight - 10 ft. (MTR, ASSY)								TH			
Twist Tight - 25 ft. (MTR, ASSY)								TJ			
Twist Tight - 75 ft. (MTR, ASSY)								TK			
Nicor - 6 ft. (MTR, ASSY)								NG			
Nicor - 25 ft. (MTR, ASSY)								NJ			
Itron - 5 ft. (MTR, ASSY)								CF			
Itron - 25 ft. (MTR, ASSY)								CJ			
Unit of Measure Totalizer/Flow Rate											
Gallons/gallons per minute								G			
Gallons/cubic feet per minute								B			
Gallons/cubic meters per second								D			
Cubic Meters/gallons per minute								C			
Cubic Meters/cubic meters per second								E			
Cubic Meters/cubic meters per minute								T			
Cubic Meters/cubic meters per hour								H			
Cubic Feet/gallons per minute								F			
Cubic Feet/cubic feet per minute								J			
Cubic Feet/cubic meters per hour								K			
Liters/gallons per minute								L			
Liters/liters per second								N			
Liters/liters per minute								P			
Liters/liters per hour								Q			
Million Gallons/gallons per minute								M			
Gallons/millions gallons per day								R			
Acre Feet/gallons per minute								A			
Second-Foot Day/cubic feet per second								S			
Custom Units								Z			
Testing & Tagging											
Factory Calibrated								F			
3rd Party Calibrated (See pricing on pg. 20)								3			
Factory Calibrated/Stainless Steel Tag								S			
3rd Party Calibrated w/ Stainless Steel Tag (See pricing on pg. 20)								T			
State of Kansas Certified								K			

Sensor Ordering Information for International

	<input type="text" value="MID"/>	<input type="text" value="2"/>	<input type="text" value="100"/>	<input type="text" value="16"/>	<input type="text" value="F"/>	<input type="text" value="St"/>	<input type="text" value="HG"/>	<input type="text" value="ML"/>	<input type="text" value="HC"/>	<input type="text" value="St"/>
Model	MID electromagnetic flow meter	MID								
Type	Type 2	2								
	Type 3	3								
	Type 5	5								
	Type 6	6								
Size	DIN 6 to DN 2000									
Pressure rate										
Process connection	DIN flanges				F					
	ANSI flanges				A					
	Threads acc. DIN 11851				D					
	Tri-Clamp®				T					
	Wafer				W					
Material	C-steel					ST				
	SST 1.4301 (ANSI 304)					V2				
	SST 1.4404 (ANSI 316)					V4				
Liner	PTFE						PT			
	(DN 6-10)						PFA			
	Hard rubber						HG			
	Softrubber						WG			
	Halar						HA			
Electrodes	Measure + empty pipe electrode							ML		
	Measure + grounding + empty pipe electrode							MEL		
Electrode material	Hastelloy C								HC	
	Tantalum								TA	
	Platinum/gold plated								PG	
	Platinum/Rhodium								PR	
Housing	C-steel									St
	SST 1.4301 (ANSI 304)									V2
	SST 1.4404 (ANSI 306)									V4

Example: - / - / - - / -

Transmitter Ordering Information for International

	<input type="text" value="M10A"/>	<input type="text" value="R"/>	<input type="text" value="15"/>	m
Amplifier	M2000 (85-265 VAC)	M20A		
	M2000 (9-36 VDC)	M20D		
Mounted/remote/cable length	Amplifier detector mounted	M		
	Remote version cable length	R		
Remote amplifier with cable length	Remote amplifier with 10 m cable length		10	
	Remote amplifier with 15 m cable length		15	
	Remote amplifier with 20 m cable length		20	
	Remote amplifier with 25 m cable length		25	
	Remote amplifier with 30 m cable length		30	

Example: m

INTENTIONAL BLANK PAGE

Control. Manage. Optimize.

ModMAG is a registered trademark of Badger Meter, Inc. Other trademarks appearing in this document are the property of their respective entities. Due to continuous research, product improvements and enhancements, Badger Meter reserves the right to change product or system specifications without notice, except to the extent an outstanding contractual obligation exists. © 2021 Badger Meter, Inc. All rights reserved.

www.badgermeter.com